

SCHEDA TECNICA N. 01

DATI E CARATTERISTICHE TECNICHE POSSONO ESSERE VARIATI SENZA IMPEGNO DI PREAVVISO

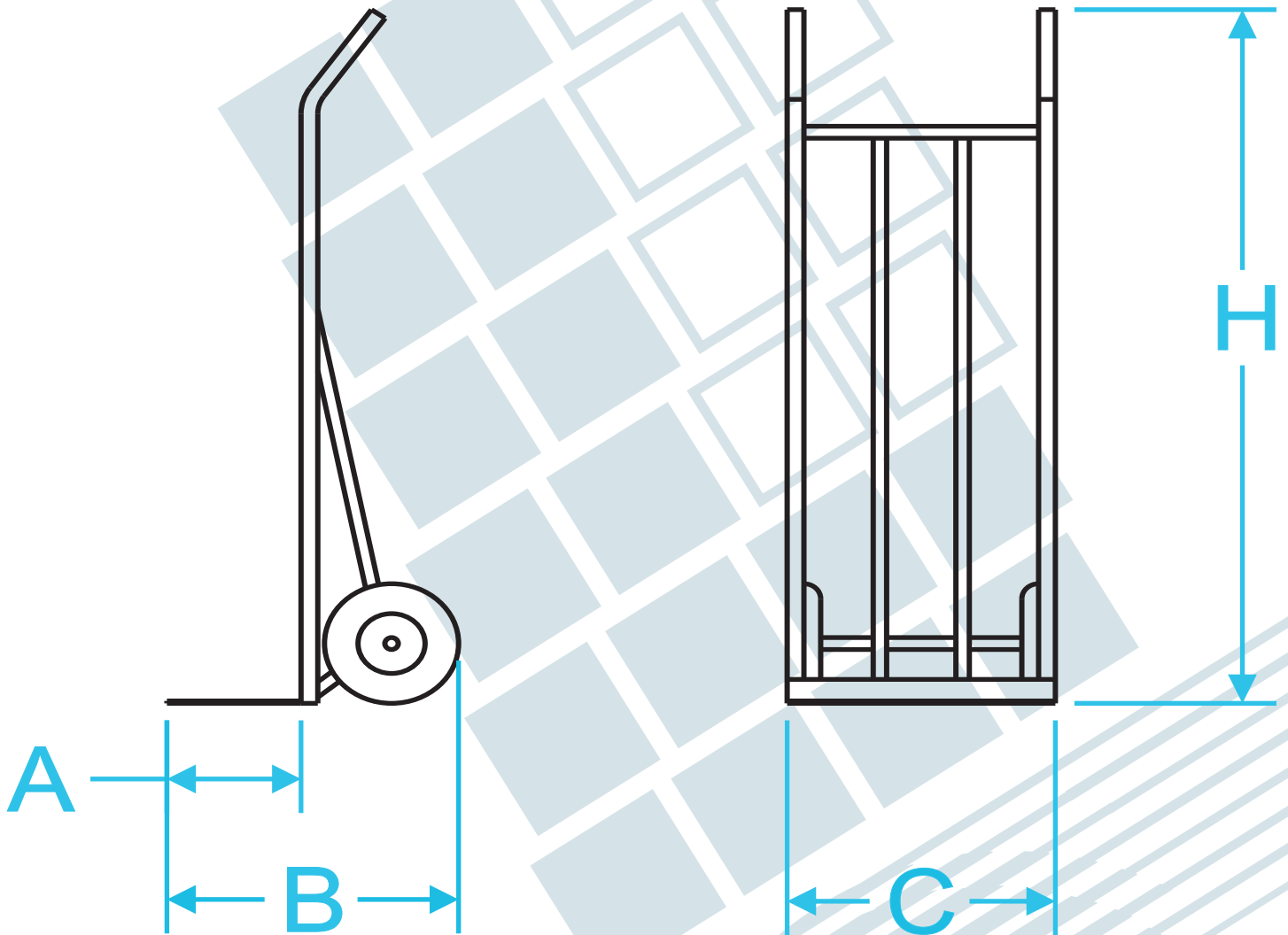

- RIFERIMENTI -

- | | | | |
|----------------|--------------|----------------|-----------------|
| - mod. 130/200 | - mod. 136 | - mod. 146/200 | - mod. 156/260G |
| - mod. 130/260 | - mod. 138 | - mod. 146/260 | - mod. 158 |
| - mod. 132 | - mod. 140 | - mod. 152 | - mod. 160 |
| - mod. 134/200 | - mod. 143/1 | - mod. 156/200 | - mod. 162C |
| - mod. 134/260 | - mod. 143/2 | - mod. 156/260 | - mod. 162F |

A RICHIESTA

ORDINE MINIMO pz.50

130/200



130/200



130/200

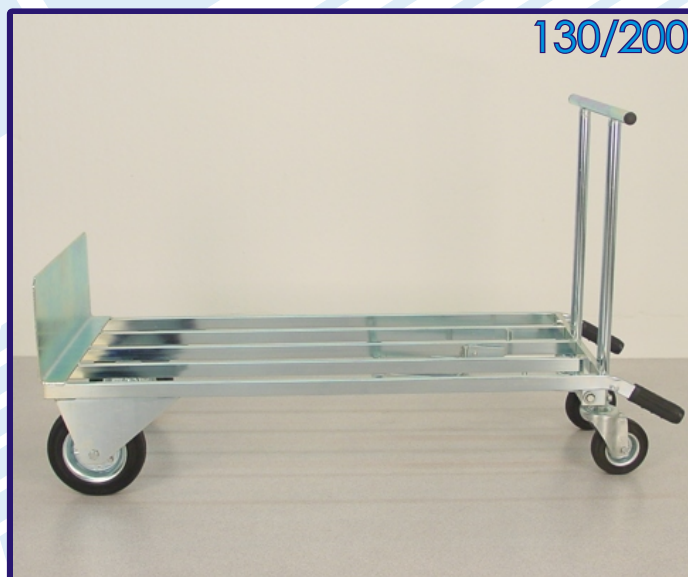

Mod. 130/200

Carrello multiuso
trasformabile in tre posizioni
ruote in gomma piena
PORTATA: Kg. 300
SCHEMA TECNICO N. 01

mod.	A	B	C	H
130/200	200	460	500	1280

REALIZZAZIONE A RICHIESTA

ORDINE MINIMO pz.50

130/260



130/260



Mod. 130/260

Carrello multiuso
trasformabile in tre posizioni
ruote pneumatiche
PORTATA: Kg. 300
SCHEDE TECNICHE N. 01

130/260



mod.	A	B	C	H
130/260	200	460	500	1280



Mod. 132

Carrello porta colli tipo leggero
ruote in gomma piena
PORTATA: Kg. 120
SCHEDA TECNICA N.01

mod.	A	B	C	H
132	150	350	400	1130

Mod. 134/200

Carrello porta colli tipo medio
ruote in gomma piena
PORTATA: Kg. 200
SCHEDA TECNICA N. 01

mod.	A	B	C	H
134/200	200	420	400	1160

Mod. 134/260

Carrello porta colli tipo medio
ruote pneumatiche
PORTATA: Kg. 200
SCHEDA TECNICA N. 01

mod.	A	B	C	H
134/260	200	500	400	1160



Mod. 136

Carrello porta colli tipo pesante
ruote in gomma piena
PORTATA: Kg. 200
SCHEDA TECNICA N. 01

mod.	A	B	C	H
136	200	610	460	1210



Mod. 138

Carrello porta colli cilindrici tipo medio
ruote in gomma piena
PORTATA: Kg. 200
SCHEDA TECNICA N. 01

mod.	A	B	C	H
138	130	480	400	1130

Mod. 140

Carrello porta colli cilindrici tipo pesante
ruote in gomma piena
PORTATA: Kg. 300
SCHEDA TECNICA N.01

mod.	A	B	C	H
140	145	550	430	1200



143/1

IN PROMOZIONE



143/2

Mod. 143/1

Carrello porta bombole a 1 posto completo di cassetta porta attrezzi ruote in gomma piena
PORTATA: Kg. 200

SCHEDA TECNICA N. 01

mod.	A	B	C	H
143/1	220	600	500	1200

Mod. 143/2

Carrello porta bombole a 2 posti completo di cassetta porta attrezzi ruote in gomma piena
PORTATA: Kg. 200

SCHEDA TECNICA N. 01

mod.	A	B	C	H
143/2	220	600	500	1200

Mod. 146/200

Carrello pieghevole tipo medio ruote in gomma piena
PORTATA: Kg. 200

SCHEDA TECNICA N. 01

mod.	A	B	C	H
146/200	220	450	400	1170



146/200



146/200



146/260



146/260

Mod. 146/260

Carrello pieghevole tipo medio ruote pneumatiche
PORTATA: Kg. 200

SCHEDA TECNICA N. 01

mod.	A	B	C	H
146/260	220	520	400	1180

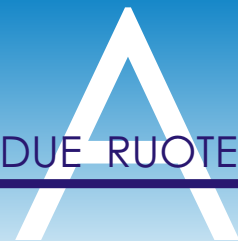

152



152

Mod. 152

Carrello montascale a 6 ruote
in gomma piena,
per carichi pesanti
PORTATA: Kg. 300

SCHEDA TECNICA N. 01

mod.	A	B	C	H
152	250	610	450	1320

Mod. 156/200

Carrello porta sacchi immondizia
con paletta pieghevole
ruote in gomma piena

PORTATA: Kg. 120

SCHEDA TECNICA N. 01

mod.	A	B	C	H
156/200	460	760	500	1160



156/200



156/200



156/260



156/260

Mod. 156 T
NOVITA'!!
TRESPOLO
PORTA
SACCHI



156 T

Mod. 156/260

Carrello porta sacchi immondizia
paletta pieghevole
ruote pneumatiche

PORTATA: Kg. 120

SCHEDA TECNICA N. 01

mod.	A	B	C	H
156/260	460	760	500	1160



Mod. 156/260G

Carrello porta sacchi immondizia
tipo grande
con paletta pieghevole
ruote pneumatiche
PORTATA: Kg. 150

SCHEDA TECNICA N. 01

mod.	A	B	C	H
156 G	790	1080	550	1250

Mod. 158

Carrello con slitte in nylon per scale
porta fusti birra e generi vari
PORTATA: Kg. 200

SCHEDA TECNICA N. 01

mod.	A	B	C	H
158	215	590	440	1300

Mod. 160

Carrello porta damigiane, vasi, colli
cilindrici in genere
ruote pneumatiche
PORTATA: Kg. 200

SCHEDA TECNICA N. 01

mod.	A	B	C	H
160	190	500	400	1130



Mod. 162 C

Carrello porta cestelli acqua e vino con
slitte nylon per scale
ruote pneumatiche
PORTATA: Kg. 200

SCHEDA TECNICA N. 01

mod.	A	B	C	H
162 C	215	510	290	1290

Mod. 162 F

Carrello porta fusti
con slitte nylon per scale
ruote pneumatiche
PORTATA: Kg. 200

SCHEDA TECNICA N. 01

mod.	A	B	C	H
162 F	240	500	400	1240

ORDINE MINIMO pz.50



MANOPOLE IN PVC mm 25/mm 28



SLITTE IN NYLON BIANCHE



SLITTE IN NYLON NERE



BULLONI IN ACCIAIO ZINCATO



mod.	∅ filetto	lungh. filetto	confez.
M8x14TEZN	mm 8	mm 14	10 pezzi
M8x14TEIX	mm 8	mm 14	10 pezzi
M8x16TEZN	mm 8	mm 16	10 pezzi
M8x50TEZN	mm 8	mm 50	10 pezzi
M8x60TSV	mm 8	mm 60	10 pezzi
M10x16TEZN	mm 10	mm 16	10 pezzi
M10x20TEZN	mm 10	mm 20	10 pezzi
M12x20TEZN	mm 12	mm 20	10 pezzi

DADI



mod.	∅ Bullone	confez.
DM8ZN	mm 8	10 pezzi
DM8IX	mm 8	10 pezzi
DM10ZN	mm 10	10 pezzi
DM10IX	mm 10	10 pezzi

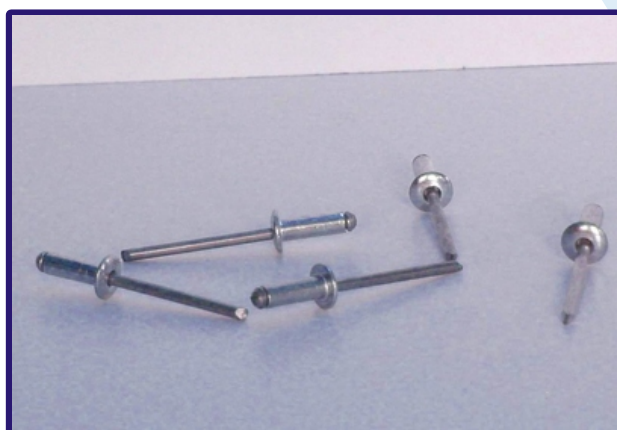

mod.	∅	lunghezza	confez.
RV516	mm 5	mm 16	10 pezzi



RONDELLE



mod.	∅ interno	confez.
RND8x24ZN	mm 8	10 pezzi
RND10x30ZN	mm 10	10 pezzi
RND15x28ZN	mm 15	10 pezzi
RND20x37ZN	mm 20	10 pezzi

RONDELLE AUTOBLOCCANTI



mod.	∅ albero	confez.
RAB15	mm 15	10 pezzi
RAB20	mm 20	10 pezzi

SEGER



mod.	∅ albero	confez.
SGR15	mm 15	10 pezzi
SGR20	mm 20	10 pezzi